



P.A. - S.p.A. - EQUIPAGGIAMENTI TECNICI DEL LAVAGGIO

VIA MILANO, 13 - CASELLA POSTALE 115 - 42048 RUBIERA (REGGIO EMILIA) - ITALY
Tel. +39 0522 623611 - Fax. +39 0522 629600 - R.E.A. RE 156319 - R. I. RE 11535 - Mecc. RE 013446
C.F. e P. IVA 01035950359 - Cap. Soc. i.v. € 750.000,00 - Codice Identificativo C.E.E. IT 01035950359
ART. 2497 - BIS C.C. DIREZIONE E COORDINAMENTO BENETTI srl R.I. TRIB. DI RE 01480690351
<http://www.pa-etl.it> - E-mail: info@pa-etl.it



VS140-VS240 - Safety Valves

Technical manual: E 220

Suitable to be utilized as safety valve on pressure washers



DN 10

- **60.1550.00** VS140 G3/8 M
- **60.1560.00** VS240 G3/8 M
- **60.1570.00** VS140 3/8NPT M
- **60.1580.00** VS240 3/8NPT M

- Central Body in Brass
- Ball seal made of Polyacetalic.
- Moving parts totally protected.
- Secure sealing to avoid leakage.
- External discharge to emphasize the intervention

TECHNICAL SPECIFICATIONS

Maximum temperature 60°C (1)

| PART NUMBER | RATED PRESSURE | PERMISSIBLE PRESSURE | MINIMUM ADJUST. PRESSURE | RESIDUAL PRESSURE DISCHARGE | (2) PRESSURE INCREASE | MAX FLOW RATE | INLET | WEIGHT |
|-------------------|----------------|----------------------|--------------------------|-----------------------------|-----------------------|---------------|-----------|--------|
| | bar - MPa | bar - MPa | bar - MPa | bar - MPa | bar - MPa | L/min | | |
| 60.1550.00 | 140 - 14 | 180 - 18 | 100 - 10 | 49 - 4.9 | 15 - 1.5 | 24 | G3/8 M | 140 |
| 60.1560.00 | 240 - 24 | 290 - 29 | 130 - 13 | 50 - 5 | 32 - 3.2 | 24 | G3/8 M | 140 |
| 60.1570.00 | 140 - 14 | 180 - 18 | 100 - 10 | 49 - 4.9 | 15 - 1.5 | 24 | 3/8NPTM M | 140 |
| 60.1580.00 | 240 - 24 | 290 - 29 | 130 - 13 | 50 - 5 | 32 - 3.2 | 24 | 3/8NPTM M | 140 |

(1) The valve has been designed for a continuous use at a water temperature of 40°C. It can resist for short periods at a maximum temperature of 60°C.

(2) **Pressure increase** = is the increase of pressure needed into the valve for discharging the max. flow when utilized at rated pressure.

Instruction manual, maintenance, installation, spare parts.

For a correct utilization, follow the directions of this manual.

Re-print them on the use and maintenance booklet of the machine.

n. 12.9220.00

DIMENSIONAL DRAWING

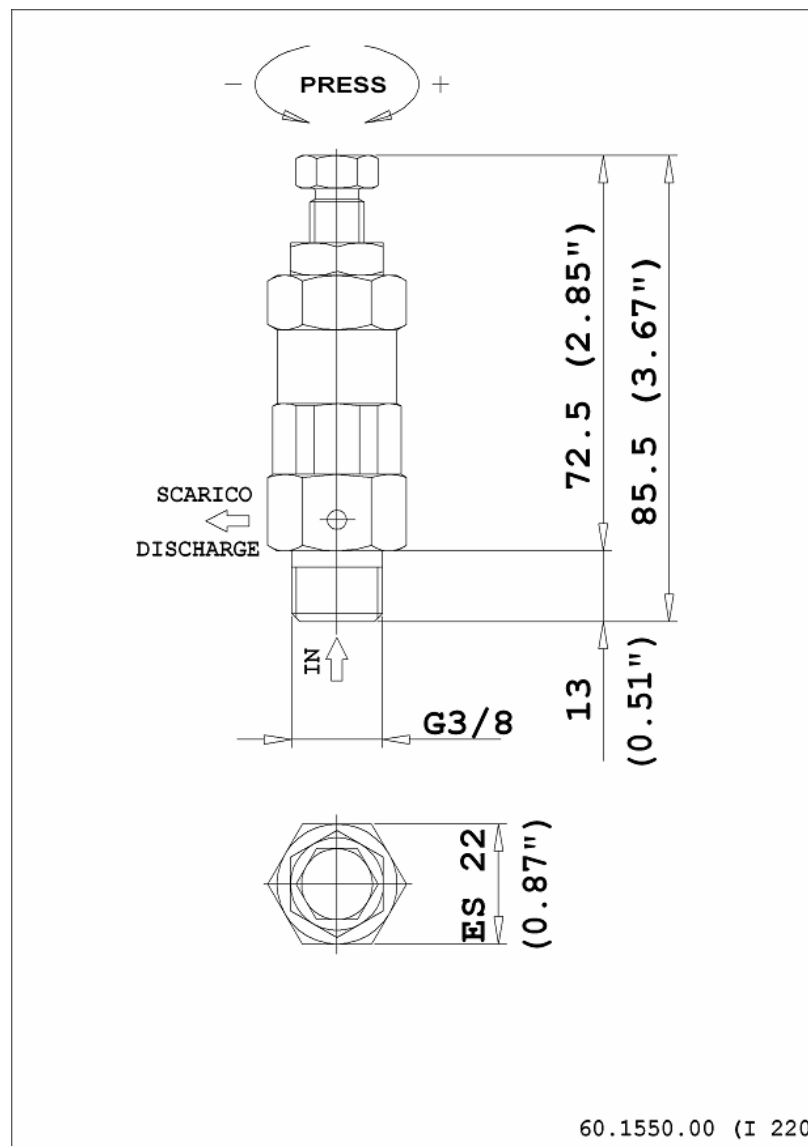

INSTRUCTIONS

SELECTION

This product is to be utilized with clean fresh water, even slightly additivated with normal detergents. For use involving different or corrosive liquids, contact the PA Technical department. Choose the valve in line with the data of nominal running (system rated pressure, max flow and max temperature). In any case, the pressure of the machine should not exceed the permissible pressure rate imprinted on the valve. The fitted valve, in line with these indications, avoids pressure spikes whilst the machine is in operation.

INSTALLATION

This accessory, on a system that produces hot water, must be fitted **in front of the heat generator**.

Utilize connection fittings in compliance to the dimensions and performance of the valve. Avoid restriction of the passage diameters which can be the cause of malfunctions, pressure reduction and duration.

ATTENTION: these valves are **not pre-adjusted**. Wrong or excessive screwing of the adjustment nut will compress the spring totally and **JAM THE VALVE COMPLETELY**.

OPERATIONS

The valve inlet is on the opposite side of the screw adjustment, the discharge port is lateral. Keep this in mind when positioning the valve in relation to the jet discharge. To re-set the working pressure, it is necessary to stop the pump in order to allow the shutter to close, check the reason of the valve intervention and then re-start the pump. After various interventions, it may be necessary to replace the ball (2) in order to maintain perfect sealing

PRESSURE ADJUSTMENT/SETTING

The adjustment has to be made in such a way that the pressure setting is not superior to the system working pressure and its accessories; this prevents the arisal of numerous pressure increases in hot water systems and static pressure (gun shut off).

PROBLEMS AND SOLUTIONS

| PROBLEMS | PROBABLE CAUSES | SOLUTIONS |
|-----------------------------------|---|---|
| Valve cycles | - Air inside the system - Seat worn out - Clogged circuit | - Flush out - Replace - Clean or widen passages |
| The valve does not reach pressure | - Unproper nozzle size - Seat worn out - Damaged nozzle | - Replace - Replace - Replace |
| Pressure spikes | - Clogged nozzle - Spring totally compressed | - Clean - Repeat adjustment & replace nozzle |
| Water leaking at discharge | - Damaged seat | - Replace |

REGULATIONS : **see norm manual**

The accessory hereby described bears the CE marking in accordance with the Norms and Directives applied on the Declaration of conformity.

For a correct utilization, follow the directions described in this manual and re-print them on the Use and maintenance manual of the machine.

Make sure that you are given **the Original Conformity Declaration** for the accessory chosen. The present manual is valid for all unloader valves named **VS140-VS240**.

MAINTENANCE

Maintenance has to be carried out by **Specialized Technicians**.

STANDARD: every 400 working hours (circa 10,000 cycles), check and lubricate the seals with water resistant grease.

SPECIAL: every 800 working hours(circa 20,000 cycles), control the wear of the seals and internal parts and if necessary, replace with original PA parts taking care during installation and to lubricate with water resistant grease.

ATTENTION: reassemble the valve in the correct manner paying special attention how to set the valve as described in the paragraph **PRESSURE ADJUSTMENT/SETTING**.

The manufacturer is not to be considered responsible for damage as a result from incorrect fitting and maintenance

Technical data, descriptions and illustrations are indicative and liable to modification without notice