

# EVOLUTION 2

## STANDARD VERSION / VERSIONE STANDARD

Mod.	Flow rate Portata		Max. press Pressione		r.p.m. g.min	Power Potenza	
	l/min	G.P.M. (U.S.A.)	bar	MPa p.s.i.		kW	hp

E2B2008	7,5	1,98	200	20	2900	1450	2,87	3,9
E2B2010	10	2,64	200	20	2900		3,82	5,2
E2B1711	11	2,91	170	17	2465		3,60	4,9
E2B1712	12	3,17	170	17	2465		3,90	5,3
E2B1713	13	3,43	170	17	2465		4,19	5,7
E2B2014	14	3,70	200	20	2900		5,37	7,3
E2B2015*	15	3,96	200	20	2900	5,44	7,4	
E2B2808	7,5	1,98	275	27,5	4000	3,97	5,4	

(\*) : Nickel plated head - *Culasse nickelée* - *Vernickelter Kopf*  
*Culata niquelada* - *Testata nichelata*

E2C2109	9	2,38	210	21	3045	1750	3,60	4,9
E2C2111	11	2,91	210	21	3045		4,41	6
E2C2112	12	3,17	210	21	3045		4,78	6,5
E2C1713	13	3,43	170	17	2465		4,19	5,7
E2C1714	14	3,70	170	17	2465		4,56	6,2
E2C1715	15	3,96	170	17	2465		4,85	6,6
E2C2016	16	4,23	200	20	2900	6,10	8,3	
E2C2809	9	2,38	275	27,5	4000	4,71	6,4	

E2D2010	9,5	2,51	200	20	2900	2800	3,60	4,9
E2D2011	11	2,91	200	20	2900		4,19	5,7
E2D2013	13	3,43	200	20	2900		5,00	6,8
E2D2015	15	3,96	200	20	2900		5,74	7,8
E2D2016	16	4,23	200	20	2900		6,10	8,3
E2D2810	10	2,64	275	27,5	4000		5,22	7,1
E2D2811	11	2,91	275	27,5	4000	5,81	7,9	
E2D2812	12	3,17	275	27,5	4000	6,32	8,6	
E2D2813	13	3,43	275	27,5	4000	6,84	9,3	

E2E2108	8	2,11	210	21	3045	3400	3,24	4,4
E2E2111	11	2,91	210	21	3045		4,41	6
E2E2113	13	3,43	210	21	3045		5,22	7,1
E2E2116	16	4,23	210	21	3045		6,40	8,7
E2E2808	8	2,11	275	27,5	4000		4,19	5,7
E2E2810	10	2,64	275	27,5	4000		5,22	7,1
E2E2812	12	3,17	275	27,5	4000	6,32	8,6	
E2E2813	13	3,43	275	27,5	4000	6,84	9,3	
E2E2815	15	3,96	275	27,5	4000	7,87	10,7	

## VERSIONS with FLANGE / VERSIONI con FLANGIA

Mod.	Flow rate Portata		Max. press Pressione		r.p.m. g.min	Power Potenza	
	l/min	G.P.M. (U.S.A.)	bar	MPa p.s.i.		kW	hp

E2C2109	9	2,38	210	21	3045	1750	3,60	4,9
E2C2111	11	2,91	210	21	3045		4,41	6
E2C1713	13	3,43	170	17	2465		4,19	5,7
E2C1714	14	3,70	170	17	2465		4,56	6,2
E2C1715	15	3,96	170	17	2465		4,85	6,6

E2B2008	7,5	1,98	200	20	2900	1450	2,87	3,9
E2B2010	10	2,64	200	20	2900		3,82	5,2
E2B1711	11	2,91	170	17	2465		3,60	4,9
E2B1712	12	3,17	170	17	2465		3,90	5,3
E2B1713	13	3,43	170	17	2465		4,19	5,7
E2B2014	14	3,70	200	20	2900		5,37	7,3
E2B2808	7,5	1,98	275	27,5	4000	3,97	5,4	

E2D2010	9,5	2,51	200	20	2900	2800	3,60	4,9
E2D2011	11	2,91	200	20	2900		4,19	5,7
E2D2013	13	3,43	200	20	2900		5,00	6,8
E2D2015	15	3,96	200	20	2900		5,74	7,8
E2D2016	16	4,23	200	20	2900		6,10	8,3
E2D2810	10	2,64	275	27,5	4000		5,22	7,1
E2D2811	11	2,91	275	27,5	4000	5,81	7,9	
E2D2812	12	3,17	275	27,5	4000	6,32	8,6	
E2D2813	13	3,43	275	27,5	4000	6,84	9,3	

E2E2108	8	2,11	210	21	3045	3400	3,24	4,4
E2E2111	11	2,91	210	21	3045		4,41	6
E2E2113	13	3,43	210	21	3045		5,22	7,1

E2E2111	11	2,91	210	21	3045	3400	4,41	6
E2E2113	13	3,43	210	21	3045		5,22	7,1
E2E2114	14	3,70	210	21	3045		5,59	7,6
E2E2116	16	4,23	210	21	3045		6,40	8,7
E2E2808	8	2,11	275	27,5	4000		4,19	5,7
E2E2810	10	2,64	275	27,5	4000		5,22	7,1
E2E2811	11	2,91	275	27,5	4000	5,81	7,9	
E2E2812	12	3,17	275	27,5	4000	6,32	8,6	
E2E2813	13	3,43	275	27,5	4000	6,84	9,3	
E2E2815	15	3,96	275	27,5	4000	7,87	10,7	

**A Version**  
Per motore  
NEMA 184 TC  
Per motore elettrico  
NEMA 184 TC

**B Version**  
Per motore  
IEC 112 B 14  
Per motore elettrico  
IEC 100-112 B 14

**C 3/4" Version**  
Per motore  
SAE J606-A  
Per motore endotermico  
SAE J606-A ext.3

**C 1" Version**  
Per motore  
SAE J609-B ext.4  
Per motore endotermico  
SAE J609-B ext.4

## STANDARD VERSION / VERSIONE STANDARD

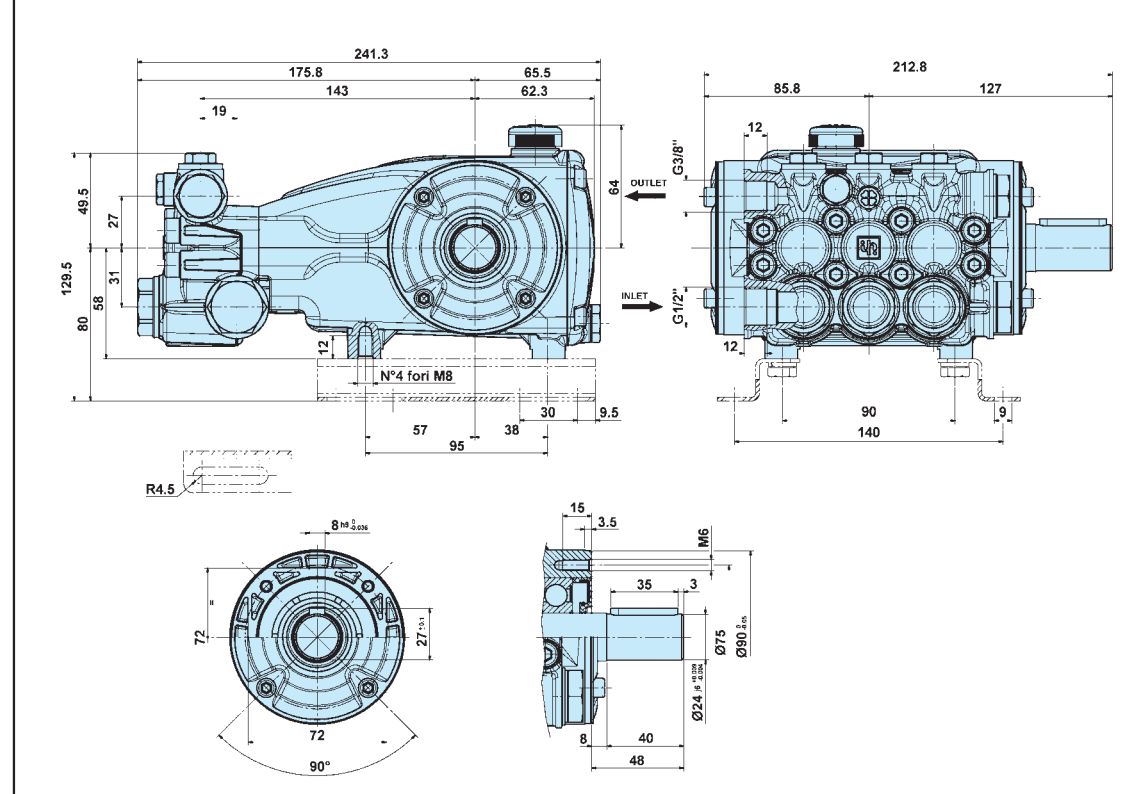

## VERSION WITH BUILT-IN AUTOMATIC UNLOADER VALVE VERSIONE CON VALVOLA AUTOMATICA INCORPORATA

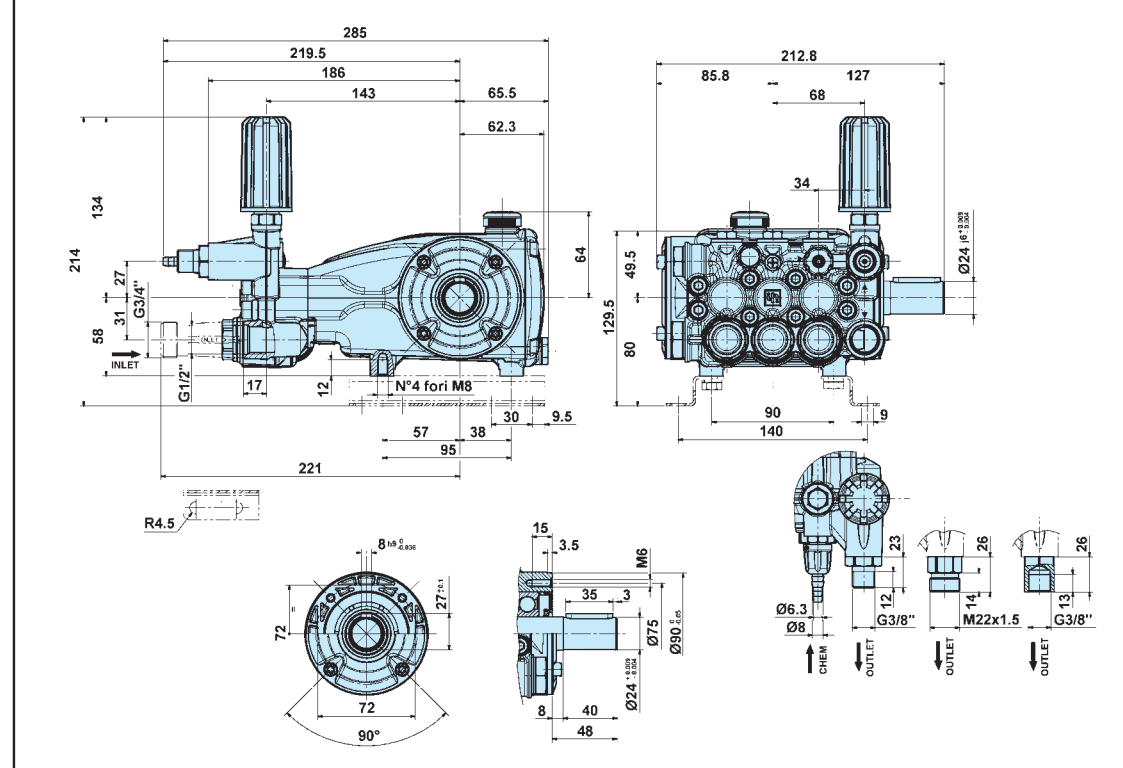

Technical data are indicative and subject to changes without notice - I dati tecnici sono indicativi e possono essere modificati senza preavviso



INTERPUMP GROUP S.P.A. - Via E. Fermi, 25 - 42049 Sant'Ilario d'Enza (RE) Italy  
tel. +39 0522 904311 fax +39 0522 904444  
E-mail: info@interpumpgroup.it - http://www.interpumpgroup.it

cod. 32.0073.03 Rev.2 08/2018



INTERPUMP GROUP

“THE BIG EVOLUTION”



E2 series

# E2 series

## EVOLUTION 2 TECHNICAL FEATURES / CARATTERISTICHE TECNICHE



E 2 - Standard version

Interpump Group, the world's largest manufacturer of plunger pumps, after having revolutionized the high pressure market with a unique product, universally acknowledged for the high technological level, introduces the new generation of pumps E2 "Evolution 2". Designed by Interpump Engineering Research Center and manufactured entirely in Italy with sophisticated automation processes, E2 represents the best synthesis of Interpump's long experience. The usual high quality standards are paired with numerous, significant technical innovations, which make the product even more performing and reliable. **Interpump Group: "The Big Evolution after the Big Revolution".**

Interpump Group, il più grande costruttore mondiale di pompe a pistoni, dopo aver rivoluzionato il settore dell'alta pressione con un prodotto unico, universalmente riconosciuto per l'alto livello tecnologico, presenta la nuova generazione di pompe E2 "Evolution 2". Progettata dal Centro Ricerche Interpump Engineering e interamente prodotta in Italia con sofisticati processi di automazione, E2 rappresenta la sintesi più completa della lunga esperienza maturata da Interpump. Agli abituali alti standard di qualità si aggiungono numerose e significative innovazioni tecniche, che rendono il prodotto ancora più performante e affidabile. **Interpump Group: "La Grande Evoluzione dopo la Grande Rivoluzione".**



E 2 - VH version



E 2 - A version



E 2 - B version



E 2 - C 3/4" version



E 2 - C 1" version

**New dual lip oil seal**  
Better oil/water sealing  
**Nuovo anello radiale a doppio labbro**  
Miglior tenuta olio/acqua



**New guiding system (Patent pending)**  
Optimal sliding of the guide-piston assembly  
Reduces friction between piston and seals  
Extension of seal life  
**Nuovo sistema di guida (Patent pending)**  
Scorrimento ottimale dell'insieme guida pistone  
Riduzione degli attriti tra pistone e tenute  
Allungamento della vita delle tenute

**1/8" pressure gauge port**  
**Attacco manometro 1/8"**

**New optimized outlet valves**  
Better volumetric efficiency  
**Nuove valvole di mandata ottimizzate**  
Migliorato rendimento volumetrico

**Inlet valves interchangeable with 63 and 44 series**  
**Valvole aspirazione intercambiabili con le serie 63 e 44**

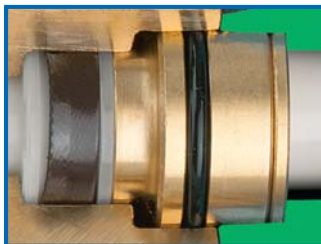

**New generation seal package with special piston guiding bush (Patent pending)**  
**Pacco pompante di nuova generazione con speciale boccola di guida pistone (Patent pending)**

**New piston fastening system**  
Eliminates the risk of pressure build-up inside the piston  
**Nuovo sistema fissaggio pistone**  
Eliminati rischi inneschi pressione all'interno del pistone



**New crankcase design**  
The oversized mechanical section reduces oil temperature  
**Carter di nuovo design**  
La meccanica maggiorata determina una riduzione della temperatura dell'olio

**Increased sliding surface of the piston guide**  
Better stability of the guide and reduced wear  
**Incrementata superficie di scorrimento della guida pistone**  
Migliore stabilità della guida e minore usura



**Large diameter oil sight glass**  
Easier oil checking  
**Spia livello olio di diametro maggiorato**  
Controllo olio facilitato

**Oil dipstick with breather**  
**Asta livello olio con sfiato**

**New design oversized connecting rods**  
Reduced specific pressure and better lubrication  
**Biella sovradimensionata di nuovo design**  
Riduzione della pressione specifica e miglior lubrificazione



**Large oil capacity**  
Better cooling and lubrication  
**Elevato contenuto di olio**  
Miglior raffreddamento e lubrificazione

**Oversized Premium Bearing**  
**Cuscinetto Premium sovradimensionato**

**New dual diameter piston guide**  
Rolled oil seal sliding surface  
Risk of oil leak reduced to a minimum  
Extension of oil seal life  
**Nuova guida pistone a doppio diametro**  
Superficie di scorrimento anello tenuta olio rullata  
Riduzione al minimo dei rischi di perdite olio  
Allungamento della vita anelli tenuta olio



**Oversized forged crankshaft**  
**Albero forgiato sovradimensionato**

**Oversized gudgeon pin**  
**Spinotto sovradimensionato**

**New dust protection chamber between crankcase and manifold**  
**Nuova camera protezione polveri fra carter e testata**

**New forged brass manifold**  
Working pressure increased to 275 bar (4000 psi)  
Available with built-in automatic unloader  
**Testata di nuovo design in ottone forgiato**  
Prestazioni incrementate a 275 bar (4000 psi)  
Disponibile versione con valvola automatica di regolazione incorporata

**New solid ceramic piston (made in Interpump) with dual guide system (Patent pending)**  
**Nuovo pistone in ceramica integrale (made in Interpump) con sistema a doppia guida (Patent pending)**

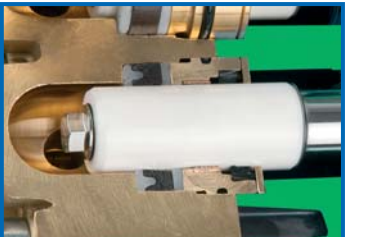

... an Italian pride  
... un orgoglio italiano